

shindaiwa[®]

SPECIFICATION

DGA37C

CONTENTS

CHAPTER 1: GENERAL STANDARDS & CONDITIONS	1
1. DESIGN STANDARDS.....	1
2. DESIGN CONDITIONS	
3. FACTORY INSPECTION	
4. PAINTING PROCESS	
CHAPTER 2: EQUIPMENT SPECIFICATIONS	2
1. OVERALL SPECIFICATION.....	2
2. DIESEL ENGINE REMARKS.....	3
3. THREE PHASE GENERATOR REMARKS	
1) Alternator	
2) Characteristic	
4. STRUCTURE	
1) Beds (bottom columns) and Vibration Proof Device	
2) Low Noise Sound-Proof Enclosure (Bonnet)	
3) Fuel Tank	
5. CONTROL DEVICES, GAUGES, and PROTECTIVE DEVICES.....	4
1) Control Device	
2) Gauges (Displays)	
3) Protection Device	
4) Output Terminals Plate	
6. ACCESSORIES.....	4
CHAPTER 3: OVERALL DIMENSIONS	5
1. FRONT VIEW.....	5
2. RIGHT SIDE VIEW	
3. LEFT SIDE VIEW.....	6
4. TOP VIEW	
5. CONTROL PANEL.....	7
6. MAIN TERMINAL BOARD.....	8
7. RECEPTACLE PANELS	
8. GENERATOR WIRING DIAGRAM.....	9
9. ENGINE WIRING DIAGRAM.....	10

CHAPTER 1: GENERAL STANDARDS & CONDITIONS

1. DESIGN STANDARD

The designs and the productions are in conformity with:

- (1) Japan Industrial Standards
- (2) The Institute of Electrical Engineering of Japan
- (3) The Japan Electric Manufactures Association
- (4) Japan Construction Mechanization Association

2. DESIGN CONDITION

- (1) Installation Place: Inside/Outside
- (2) Ambient Temperature: -15°C to +35°C
- (3) Humidity: Less than 80%
- (4) Altitude: Below than three hundreds (300) meters above sea Level

3. FACTORY INSPECTION

The inspection test shall be done for the complete unit of Diesel Engine and portable Generator Unit.

- (1) Inspection items
- (2) Insulation and Dielectric Tests
- (3) Starting ability
- (4) Protection Devices Working Test
- (5) Voltage Deviation and Speed Variation: 1/4, 2/4, 3/4 and 4/4 Load
- (6) Load Test: 4/4 Load 30 minutes

4. PAINTING PROCESS

- (1) Painting process specifications and colors are based on the Manufacturer's standard

CHAPTER 2: EQUIPMENT SPECIFICATIONS

1. OVERALL SPECIFICATION

Item	Model	DGA37C-Ultra Quiet
ALTERNATOR		
Generator Type	Revolving Field Brushless AC Generator	
Frequency (Allowance)	(Hz)	50 (Less than 5%)
Rated output	(kVA)	37.5
	(kW)	30
Rated voltage (1 phase) (3 phase)	(V)	240 415
Rated amperage (1phase, 240V) (3phase, 415V)	(A)	15 51.5
Voltage Allowance (1phase)	%	±2.5
Voltage Allowance (3phase)	%	±1.0
Rated speed(50/60Hz)	(min ⁻¹)	1500
Winding	—	3phase, 4-wire star with Neutral/Zigzag
Rated power factor	—	0.8 (Lagging)
Number of polarity	Poles	4
Sound level, No load at 23ft	dB(A)	53
Sound level, Full load at 23ft	dB(A)	56
DIESEL ENGINE		
Make, model, type	—	ISUZU, 4JG1T, Water cooled 4cylinder
Design features	—	Direct injection, Turbo-charged
Displacement	(L)	3.059
Bore x stroke	(mm)	95.4x107
Continuous rated output	(kW)	35.4 (1500 min⁻¹)
Starting system	—	Electric 12V DC
Internal Fuel tank capacity	(L)	124
Fuel consumption, Full load 3/4 load 1/2 load 1/4 load	(L/hr)	10.4*
		7.8*
		5.6*
		3.6*
Fuel classification	—	Diesel fuel ASTM No. 2 or Equivalent
Lubricating oil type	—	Class CC or better, SAE30
Lubricating oil capacity	(L)	10
Coolant capacity	(L)	13
Battery	—	95D31R
5-hour capacity	(Ah)	64
Dimensions L×W×H	(mm)	1770×920×1350
Unit dry weight	(kg)	1140

Note: The indicated values as (*) were obtained under specified operating condition.
Use the numerical value as reference only.

2. DIESEL ENGINE REMARKS

Make, model : ISUZU 4JG1T
Fuel Filter : Paper Filter
Automatic Air Extraction : Standard Accessory
External Fuel Changeover: Standard Accessory

3. THREE PHASE GENERATOR REMARKS**1) Alternator**

Model : Rotating Field, Self-Ventilation
Exciting Method: Brushless, AC Exciter
Wiring : Star, 3-Phase 4-Wire, Zig-zag
Insulation : Stator Wiring Class F
: Rotor Wiring Class B

2) Characteristic

Voltage Deviation: Less than $\pm 1.0\%$ for the nominal value
: Transient Values to be less than 20% (100%kVA, Power Factor 0.4)
Over-speed Endurance: 2 minutes of 120% of the rated speed
Wave Distortion: Less than 2% (3-Phase, Line to Line, No Load)
Generator Efficiency: More than 85%
Insulation Resistance: More than 5M Ω
Dielectric Insulation: 1500V for One (1) minute or 1800V for One (1) second

4. STRUCTURE**1) Beds (bottom columns) and Vibration Proof Device**

Alternator is coupled directly with engine and they are installed on the bed through vibration proof device (Rubber Pad and Angle).

2) Low Noise Sound-Proof Enclosure (Bonnet)

The structure is that the inside of the bonnet is sound-proof treated and you can lift up the alternator and the engine together with the beds by using a lifting lug.

3) Fuel Tank

The fuel tank is made of steel and incorporated with the electric type gauge.

5. CONTROL DEVICES, GAUGES, and PROTECTIVE DEVICES

1) Control Device

Breaker: **Main Circuit Breaker (Rate 600V 30A)**
:3phase circuit Breaker (Rate 415V 20A)
: 1phase circuit Breaker (Rate 240V 16A)
 Exciter Circuit: **Automatic Voltage Regulator (F/V Characteristic)**

2) Gauges (Displays)

AC Volt Meter : **0-600V**
 AC Ampere Meter : **0-75/150A**
 Frequency Meter : **45-65Hz**
 Hour Meter : **9999.9Hr (Max)**
 Oil Pressure Gauge
 Water Temperature Gauge
 Preheat Lamp
 Warning Display Lamps: High Water Temperature, Low Oil Pressure,
 Insufficient Charging
 Voltage Adjuster: Adjustable Range; Below-10%- and over +5%
 Panel Light
 Voltmeter Change-over Switch
 Ammeter Change-over Switch

3) Protection Device

Item	Set Value	Display	Trip	Shut-Down
Low Oil Pres.	98.1kPa	○	-	○
High Water Temp.	105°C	○	-	○
Insufficient Charging	-	○	-	-
Over Current (Thermal relay)	120%	-	○	-

4) Output Terminals Plate

4(four) receptacles of IP66. 3phase/15A X 1, 1phase/20A X 3
 *IP(Ingress Protection) of IEC(International Electrotechnical Commission)

6. ACCESSORIES

Fuse : 10A one piece
 Instruction manual
 Manual, engine

CHAPTER 3: OVERALL DIMENSIONS

1. FRONT VIEW

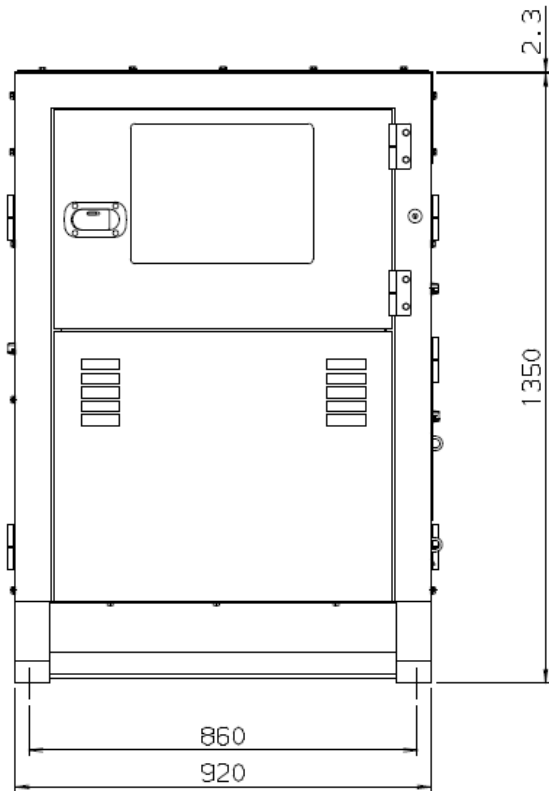

2. RIGHT SIDE VIEW

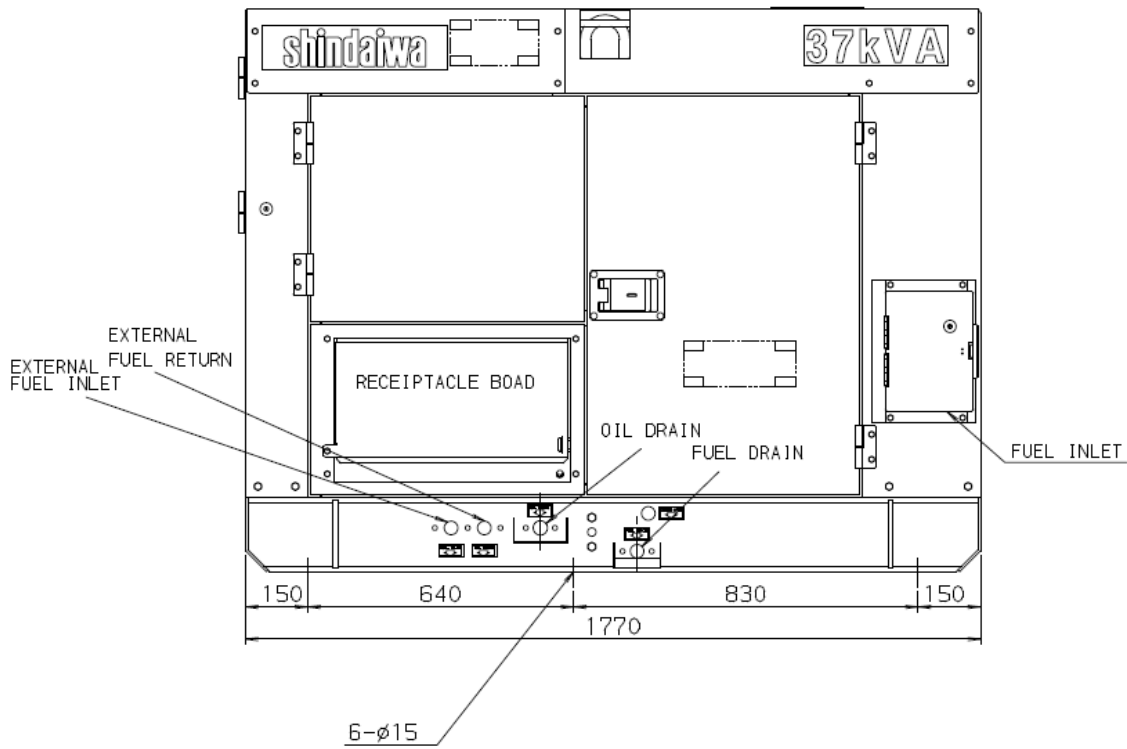

3. LEFT SIDE VIEW

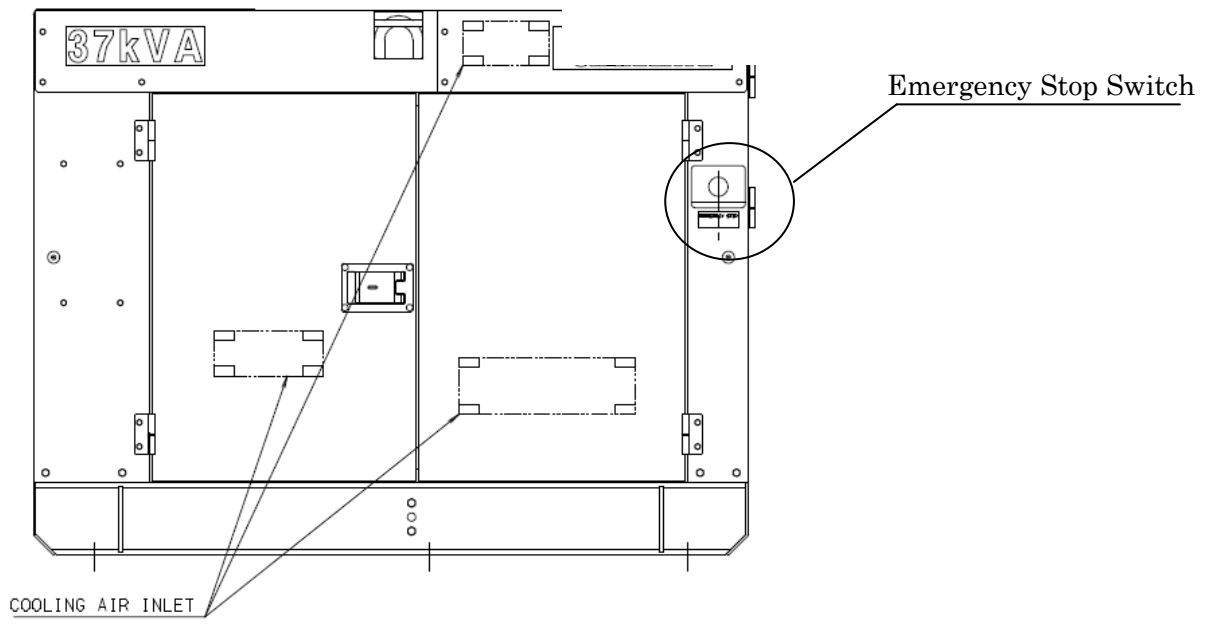

4. TOP VIEW

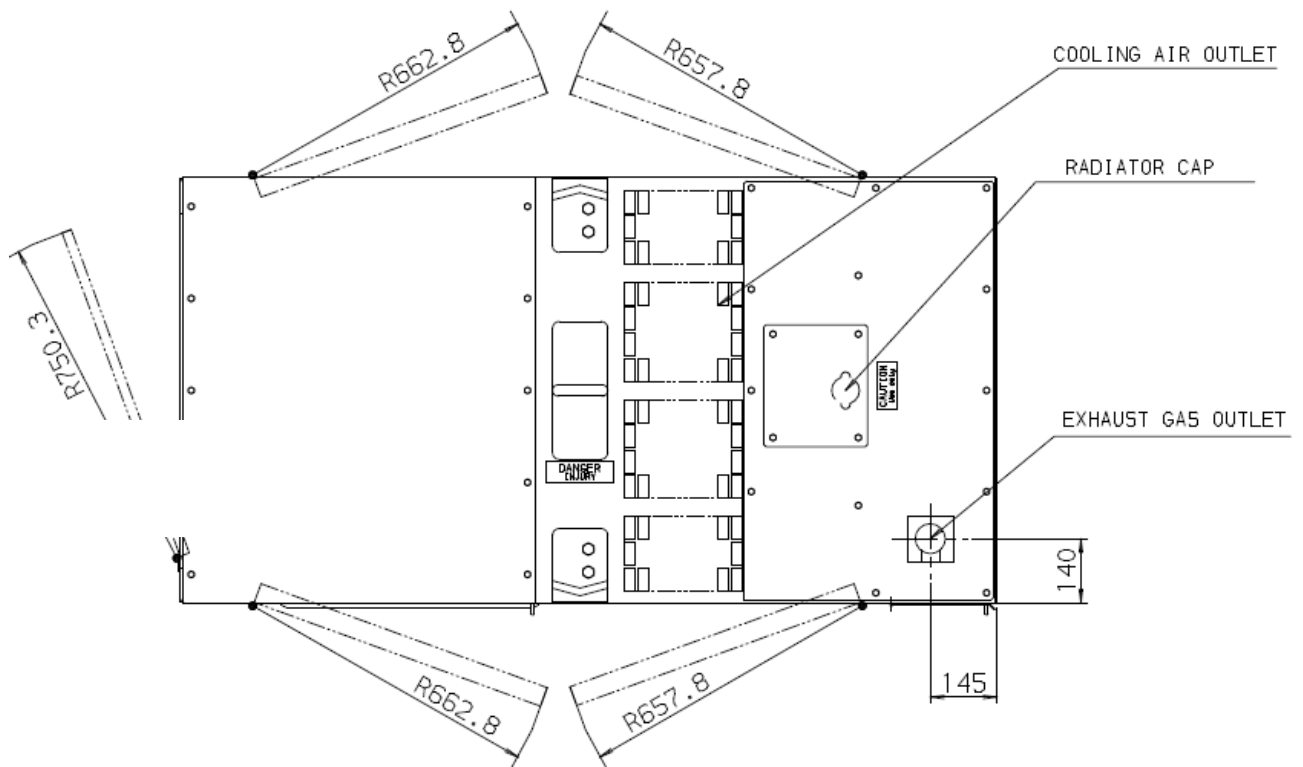

5. CONTROL PANEL

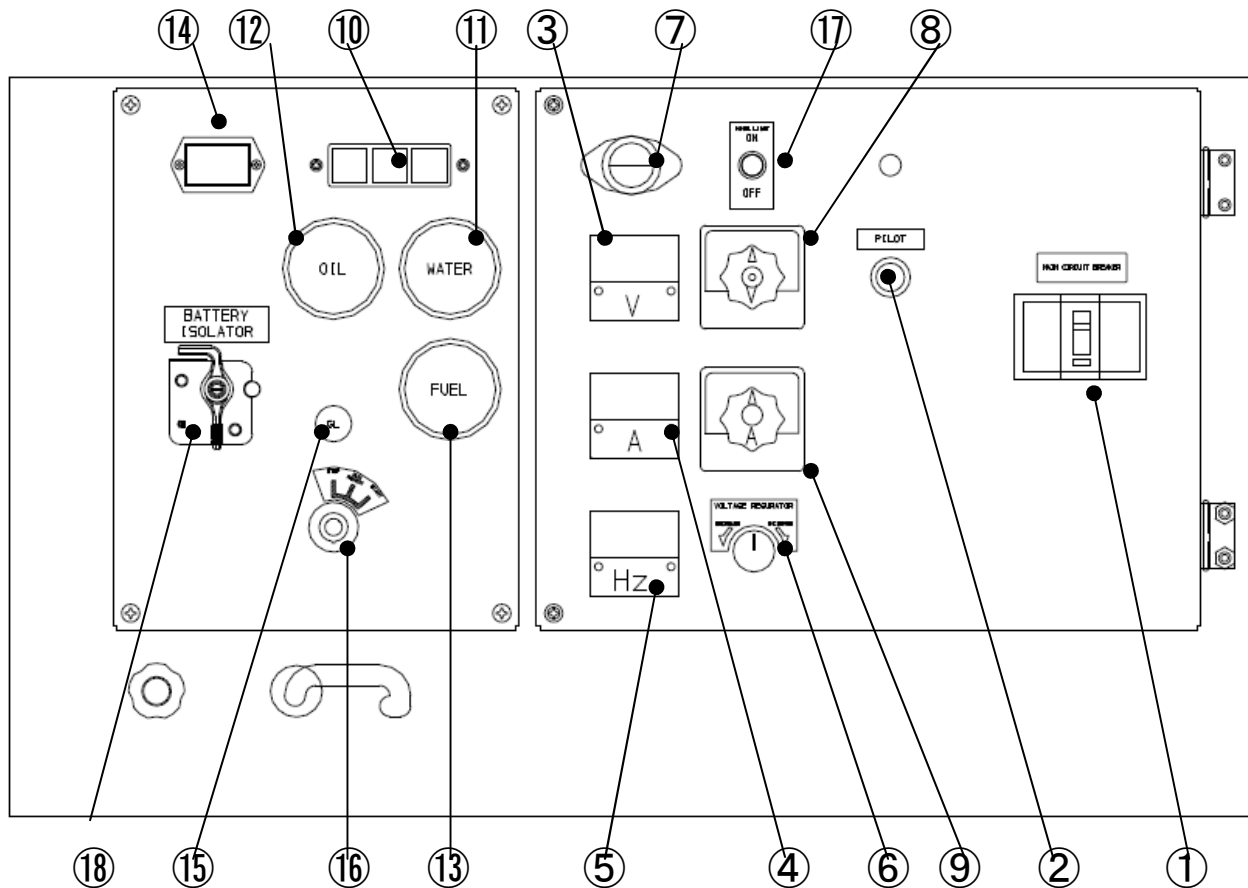

NO.	Name	Description of function
1	3-phase circuit breaker	Turns the power supply to load equipment ON (closed) and OFF (open).
2	Pilot lamp indicator	Turn on when the engine is running
3	Voltage meter	Indicates voltage.
4	AC ampere meter	Indicates phase current.
5	Frequency meter	Indicates electricity frequency.
6	Voltage selector dial	Enable to select from three positions to change the generator output voltage. Never operate while engine is running.
7	Panel light	Illuminates control panel surface and gauges
8	Voltmeter selector switch	Used to select from one of five positions for voltage. in each phase with OFF position
9	Ammeter selector switch	Used to select from one of five positions for amperage. in each phase with OFF position
10	Warning indicator	Turn on when an equipment malfunction occurs.
11	Coolant temperature gauge	Indicates temperature of the engine coolant.
12	Oil pressure. gauge	Indicates lubricating oil pressure.
13	Fuel meter	Indicates internal fuel tank remaining level.
14	Hour meter	Indicates operating hours of the generator unit.
15	Glow lamp indicator	The indicator lights when the key switch is set to the [ON] position, and starts pre-heating.
16	Starter switch	OFF: stops engine operation. START: starts an engine operation ON: supplies electricity for control operation, and starts pre-heating.
17	Panel light switch	Turn the panel light ON and OFF
18	Battery Isolator	Turn the lever to the right side for power supply.

6 .RECEPTACLE PANELS

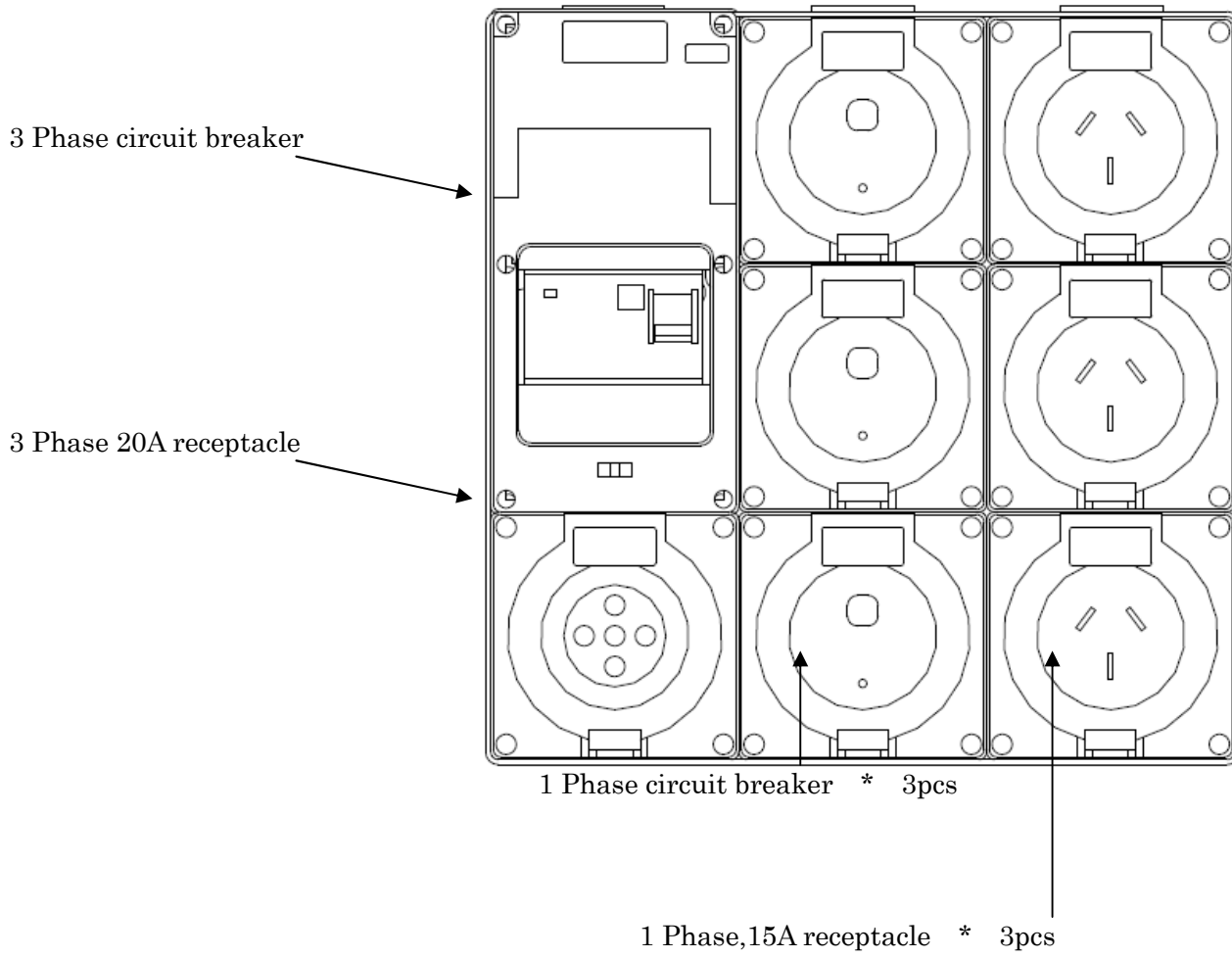

7. GENERATOR WIRING DIAGRAM

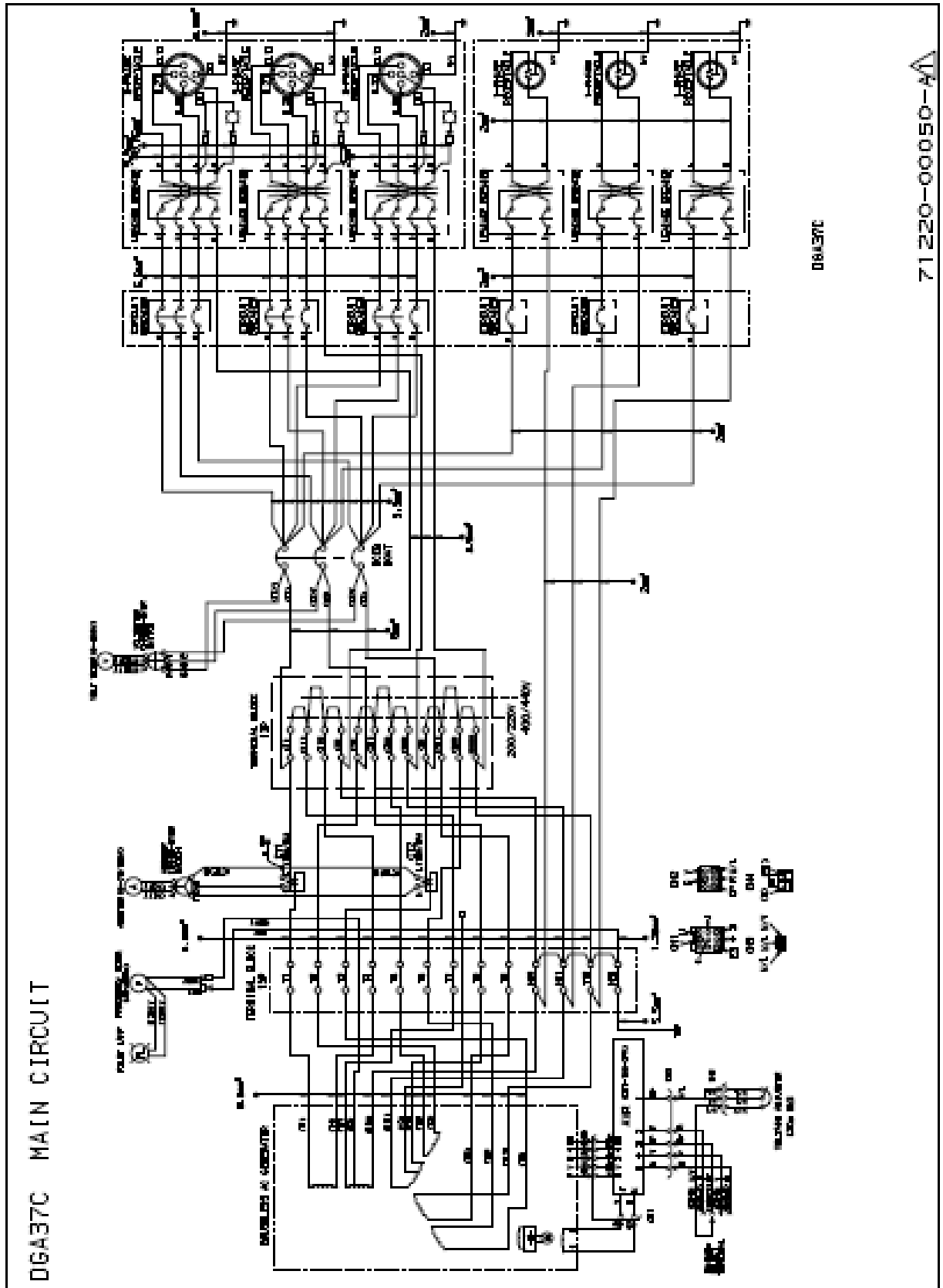

DGA37C

71220-00050-A

8. ENGINE WIRING DIAGRAM

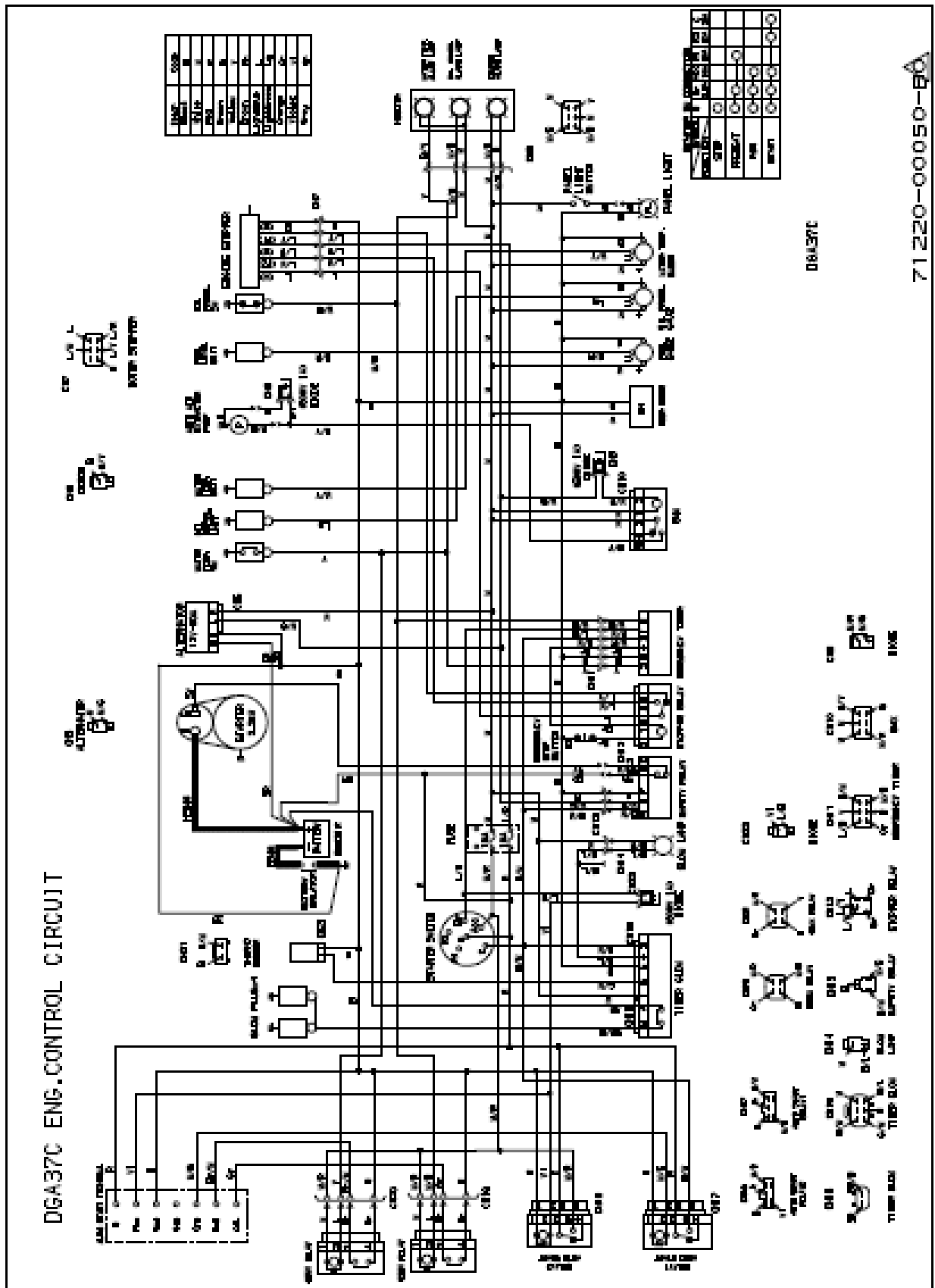

YAMABIKO CORPORATION

7-2 SUEHIROCHO 1-CHOME, OHME, TOKYO 198-8760, JAPAN
PHONE: 81-428-32-6118. FAX: 81-428-32-6145.

shindaiwa[®]